

Electro-Hyd. Circuit - JumboZ-2800

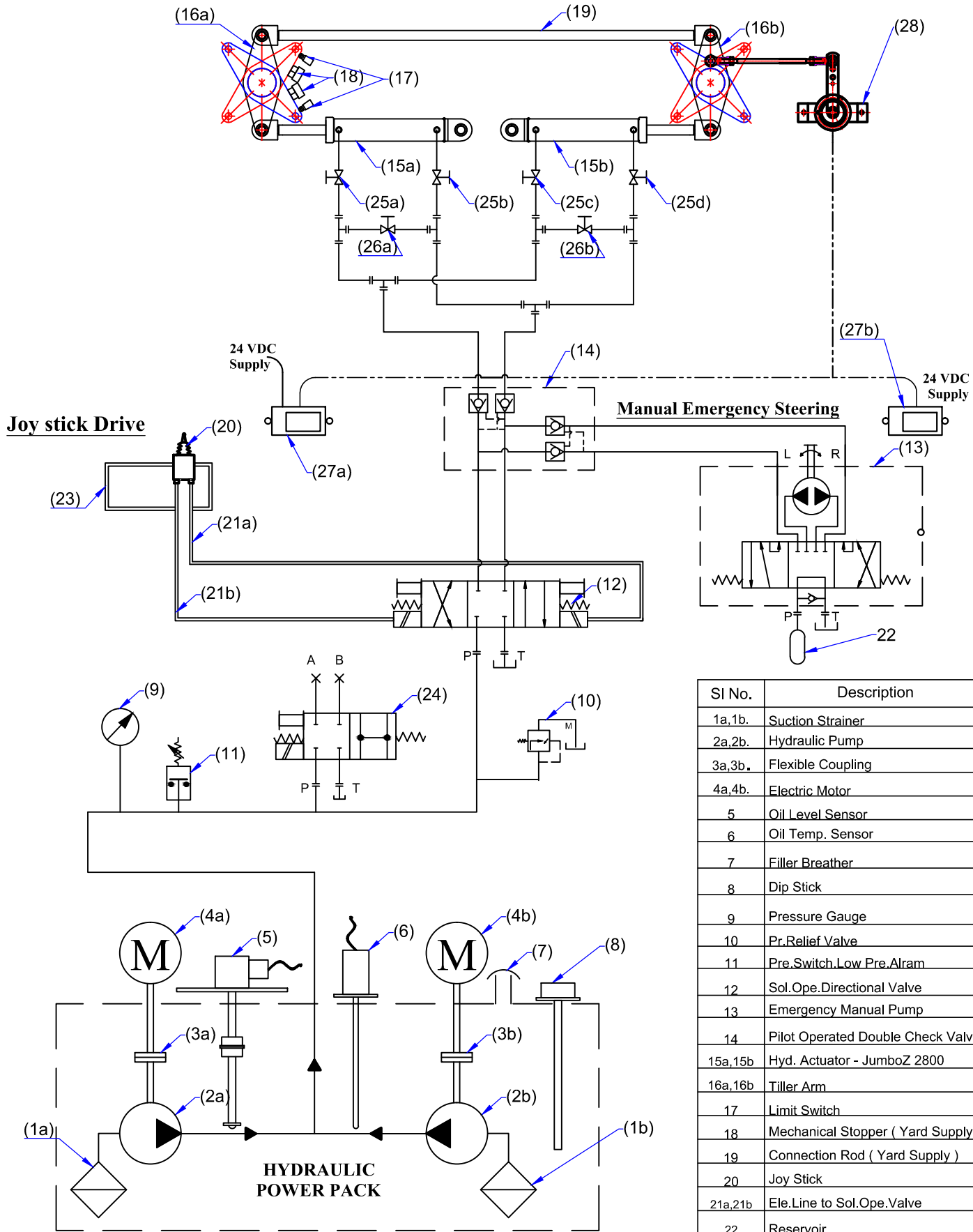

SI No.	Description
1a,1b.	Suction Strainer
2a,2b.	Hydraulic Pump
3a,3b.	Flexible Coupling
4a,4b.	Electric Motor
5	Oil Level Sensor
6	Oil Temp. Sensor
7	Filler Breather
8	Dip Stick
9	Pressure Gauge
10	Pr.Relief Valve
11	Pre.Switch.Low Pre.Alram
12	Sol.Ope.Direction Valve
13	Emergency Manual Pump
14	Pilot Operated Double Check Valve
15a,15b	Hyd. Actuator - JumboZ 2800
16a,16b	Tiller Arm
17	Limit Switch
18	Mechanical Stopper (Yard Supply)
19	Connection Rod (Yard Supply)
20	Joy Stick
21a,21b	Ele.Line to Sol.Ope.Valve
22	Reservoir
23	Steering Gear Control Panel
24	Unloading Valve
25a,25b 25c,25d	Isolation Valve
26a,26b	By-Pass Valve
27a,27b	Rudder Angle Indicator
28	Rudder Angle Sensor



**MAC ♦ N ♦ HOM SYSTEMS
KOCHI - 20**

DESIGNATION

Electro-Hydro. Circuit Twin Rudder
with Emer.Steering - JumboZ-2800E

DWG. No.

MHS-1300

DATE

16.11.2021

A

B

C

D

E

F

G

H